

Описание товара

Оригинальный лучший бренд,
Проверка качества
Пункт №.: Best-507 250G Паяльная паста
Диапазон: ноутбук / компьютер / мобильная / бытовая техника SMD IC и BGA IC Ремонт,
инструмент уровня чипремонт Линия производства электроникиОтказ

SOLDER PASTE

low temperature



500g

Low residue / Rapid welding / Solder spot bright

Product Usage



MODEL	BST-508
SHELF LIFE	6 months
INGREDIENT	Sn63/Pb37
WEIGHT	500g
MELTING POINT	183°C

Having a large insulation resistance does not corrode the PCB, and the requirements for no-cleaning can be achieved.

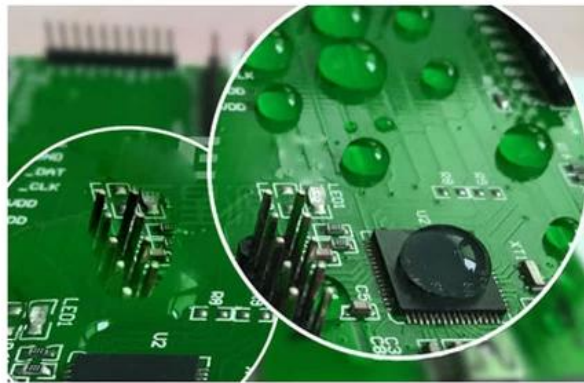

High impedance, full and bright solder, low residue

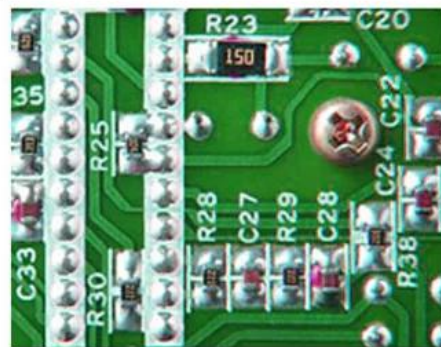
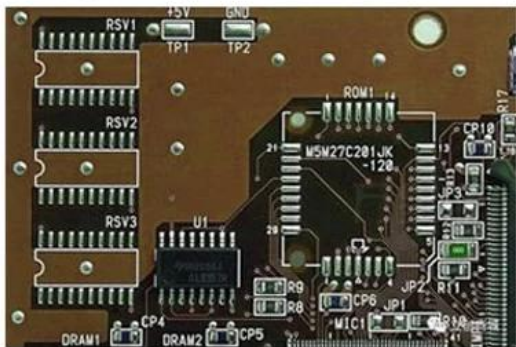

Welding requirements for a wide range of products



UNIFORM SOLDER JOINT
LOW TEMPERATURE MELTING POINT



PRODUCT SIZE



63.0MM



75MM

52MM

