

MELHORES pinças de aço inoxidável para extensão de cílios

Descrição do produto:

1. Pinças são feitas de aço inoxidável de alta qualidade, vem em acabamentos foscos;
2. Alta precisão com máximo conforto ao trabalhar com extensões de cílios.
3. As pinças são muito leves e fáceis de manusear, ajudam a reduzir a pressão das mãos;
4. Altamente preciso, sem deslizamento e antimagnético.
5. Usando as pinças corretas, isso ajudará a reduzir o tempo total de aplicação.
6. amplamente utilizado, pode ser usado para trabalhos de beleza, reparação eletrônica, instrumentos de precisão, microeletrônica ect.

Especificações:

Pinças de aço inoxidável modelo BEST

Material: aço inoxidável de qualidade

Tratamento de superfície: acabamentos foscos

Tipo de ponta Aguçado, Triângulo, Reto, Curvo, Plano

Cor luz mate

Tamanho (L * W * Ponta):

110mm~160mm

Pacote: Blister cartão

Embalagem: 20 peças/caixa

Peso do pacote: 0,6 kg/caixa

PRODUCT DISPLAY



PRODUCT SIZE

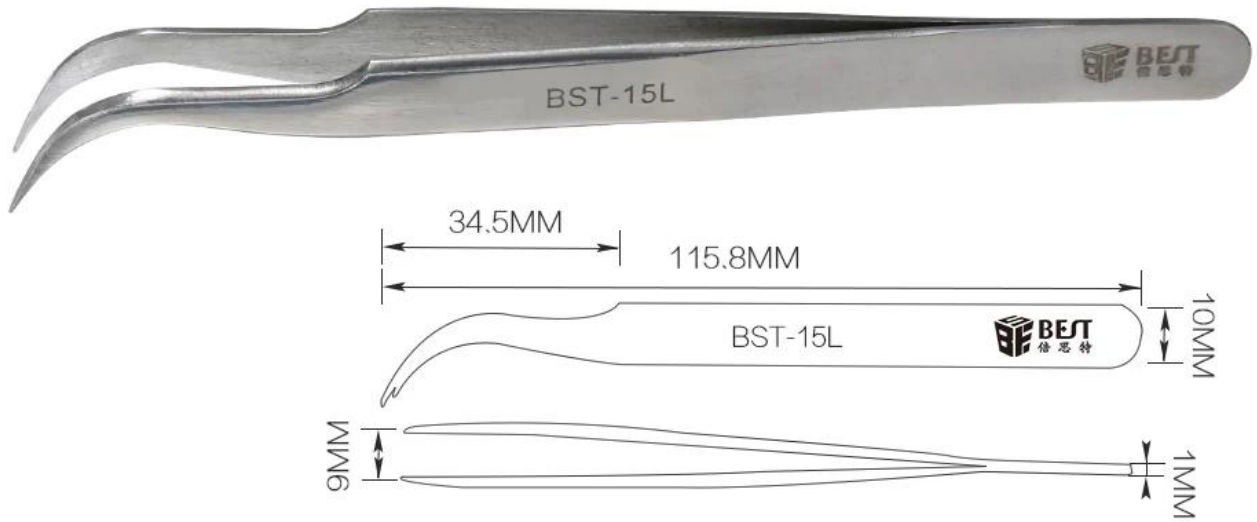

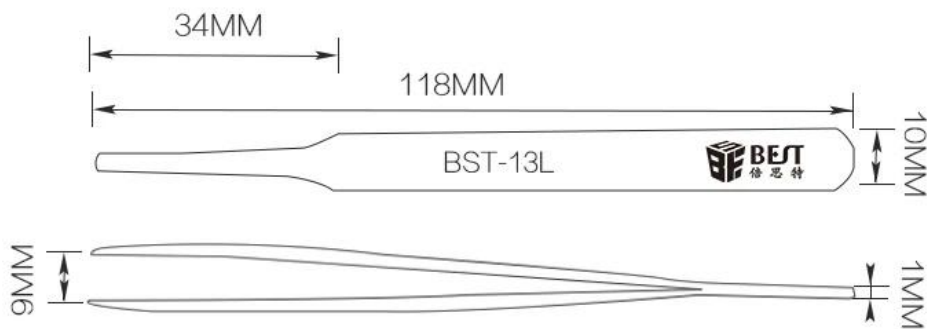
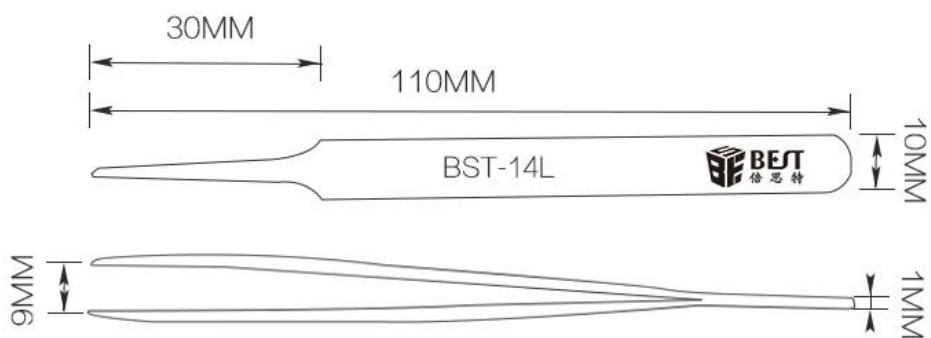
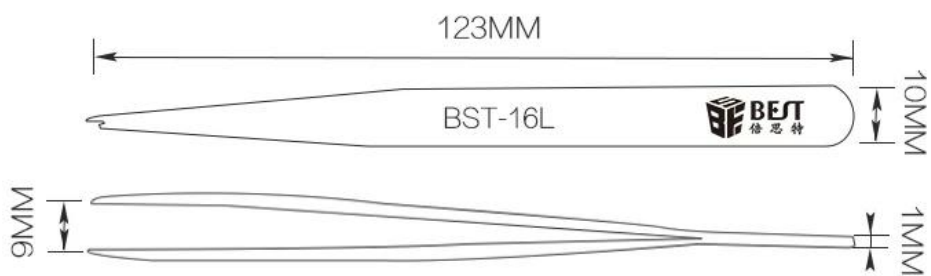

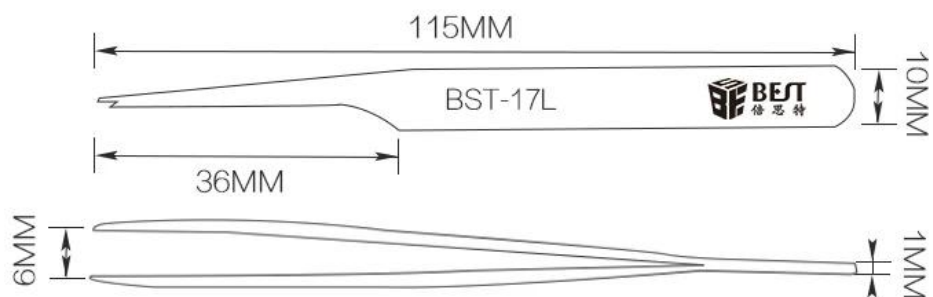
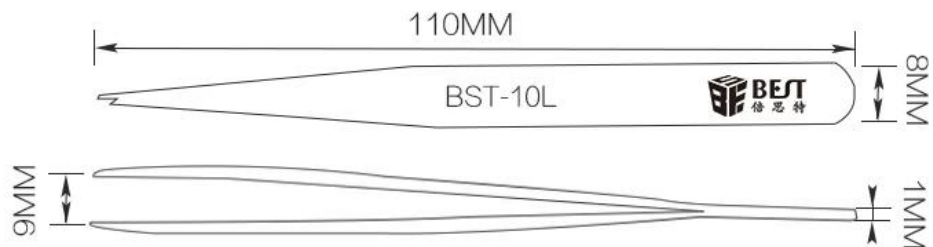
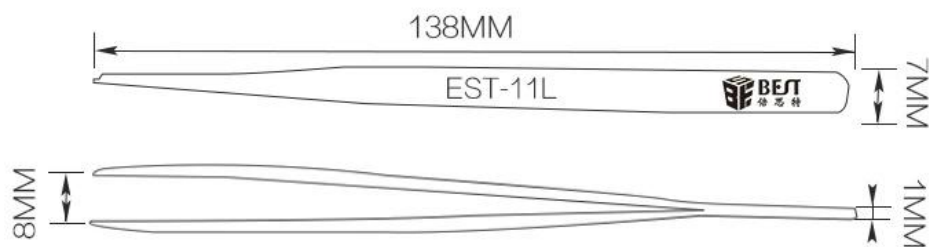
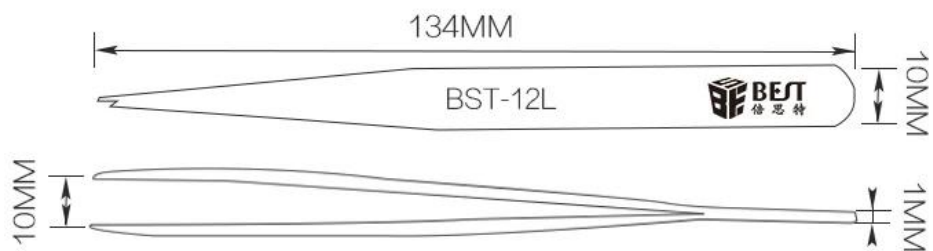

PRODUCT DETAILS



BST-10L



BST-11L



BST-12L



BST-13L



BST-14L



BST-15L



BST-16L



BST-17L

PRODUCT PHOTOGRAPH



PRODUCT PACKAGING

