

Le MIGLIORI pinzette in acciaio inossidabile per extension ciglia

Descrizione del prodotto:

1. Le pinzette sono realizzate in acciaio inossidabile di altissima qualità, sono disponibili con finiture opache;
2. Alta precisione con il massimo comfort quando si lavora con le extension ciglia.
3. Le pinzette sono molto leggere e facili da maneggiare aiutano a ridurre la pressione della mano;
4. Altamente preciso, antiscivolo e antimagnetico.
5. Utilizzando le pinzette corrette, aiuterà a ridurre il tempo complessivo di applicazione.
6. Ampiamente usato, può essere utilizzato per lavori di bellezza, riparazioni elettroniche, strumenti di precisione, microelettronica ecc.

Specifiche:

Pinzetta modello BEST in acciaio inox

Materiale: acciaio inossidabile di qualità

Trattamento superficiale: Finiture opache

Tipo di punta Appuntita, Triangolare, Diritta, Curva, Piatta

Colore Luce opaca

Taglia (L*W*Punta):

110mm~160mm

Pacchetto: blister carta

Imballaggio: 20 pezzi/scatola

Peso della confezione: 0,6 kg/scatola

PRODUCT DISPLAY



PRODUCT SIZE

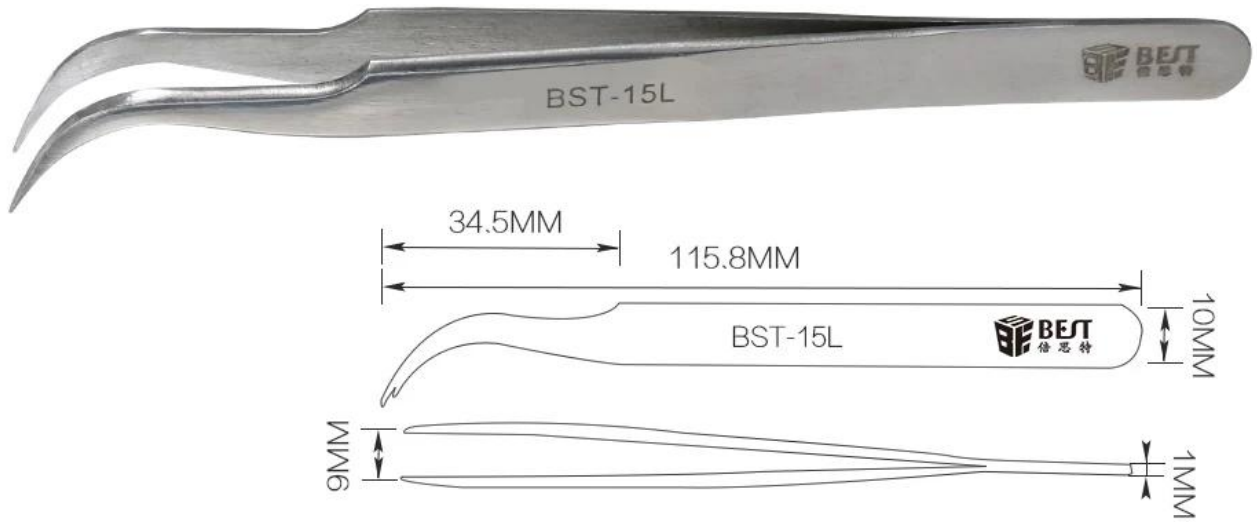

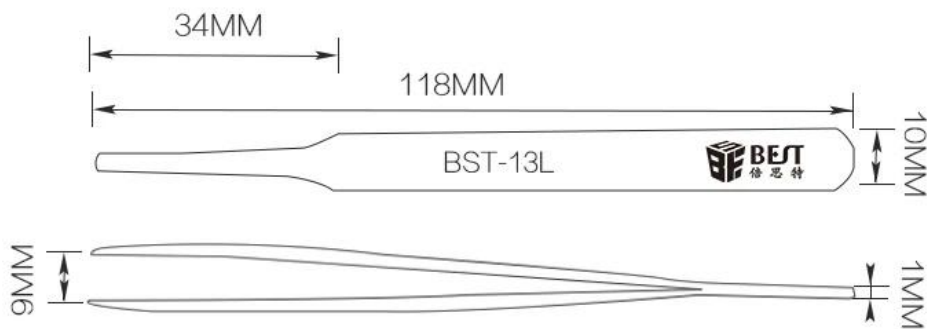
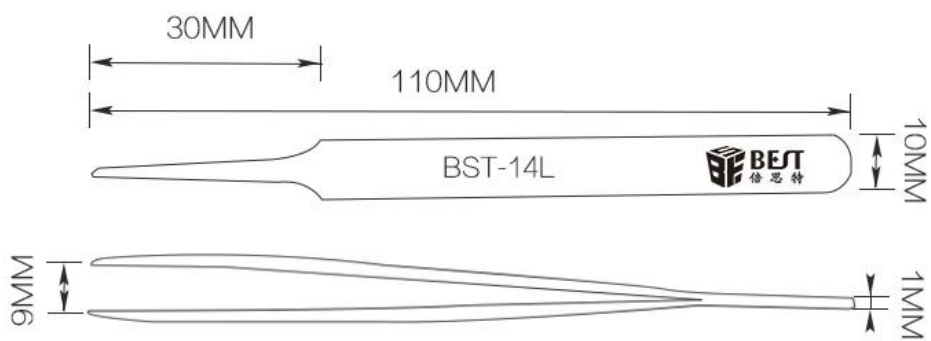
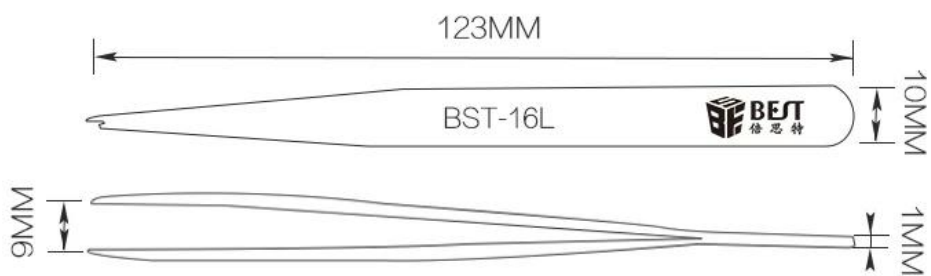

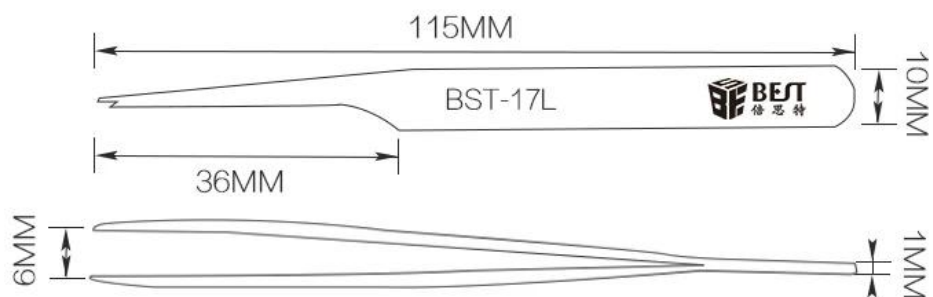
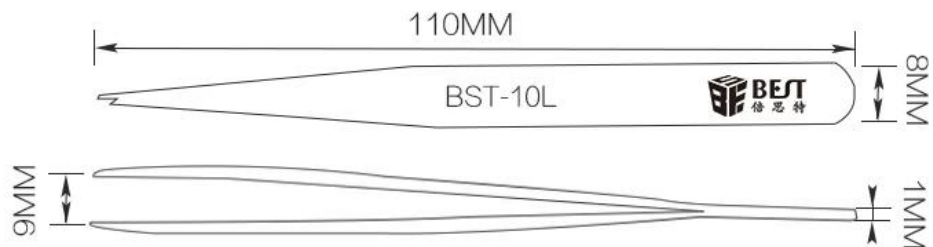
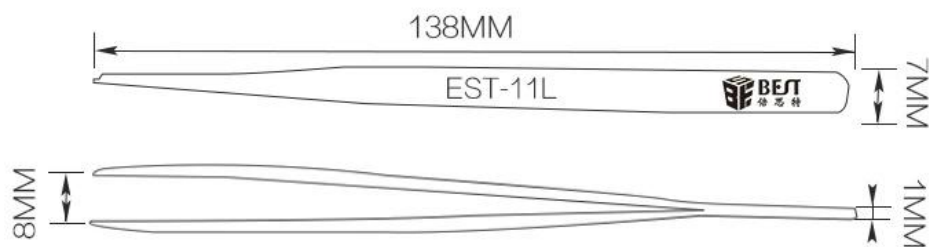
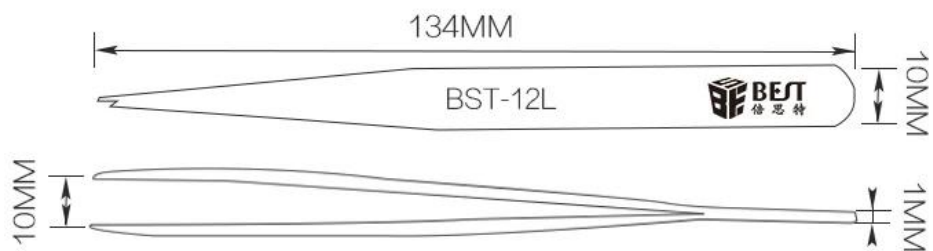

PRODUCT DETAILS



BST-10L



BST-11L



BST-12L



BST-13L



BST-14L



BST-15L



BST-16L



BST-17L

PRODUCT PHOTOGRAPH



PRODUCT PACKAGING

